

# LEDDR5CHAN Manual

# SCENE LIGHTING®

## 5 Channel DMX Driver



**Important:** Read All Instructions Prior to Installation

### Function introduction

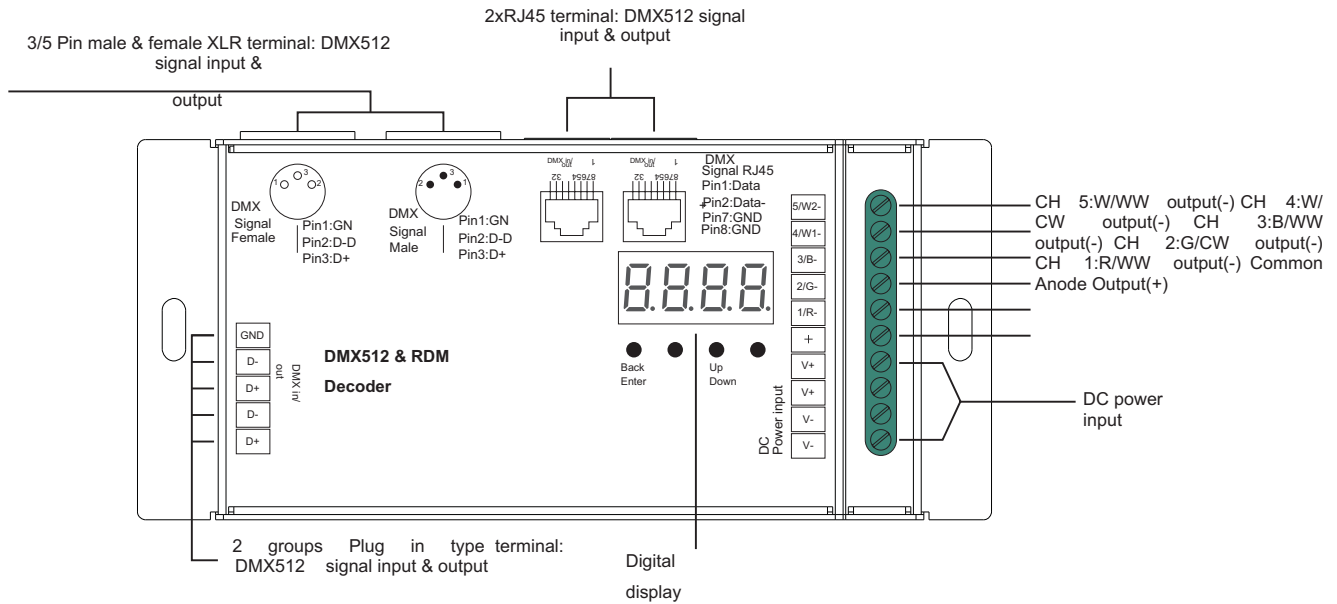

- Master & decoder mode, RDM function
- Metal housing, digital display to show data directly, easily to set and show DMX address.
- With multiple kinds of DMX in/out ports: RJ 45, XLR , normal screws.
- Total 5 PWM output channels, common anode. DMX channel quantity from 1CH~5CH settable
- PWM output resolution ratio 8bit , 16bit settable.
- Output PWM frequency from 500HZ ~ 30K HZ settable.
- Output dimming curve gamma value from 0.1 ~ 9.9 settable.
- Decoding mode settable.
- Galvanic isolation

### Safety & Warnings

- DO NOT install with power applied to device.
- DO NOT expose the device to moisture.

### Operation

Before you do other settings, please set the device to be Master or Decoder mode.

*run1* = DMX Decoder mode, *run2* = DMX Master mode(stand alone).

Keep on clicking "Down" button, to get run1 or run2, then click "Enter", then click "Down" button to choose 1 or 2, then click "Back" button.  
After choose run1 or run2, please power off and power on again the device.

**I. For run2 DMX Master mode:** After power on the device, if keep on clicking "Up" button, you will find below menu on display:

### Product Data

Voltage Input	Output Current	Output Power	Remarks	Size(LxWxH)
12-24VDC	5x8A	5x(96-192)W	Constant voltage	164x73x38mm
12-48VDC	5x350mA	5x(4.2-16.8)W	Constant current	164x73x38mm



**0.0.0.0** Means brightness for each output PWM channel. First 1 means PWM output channel 1 and it is selectable from 1 to 5 by clicking "UP" or "Down" button. Second 01 means brightness level, click "Enter" button, the display flashes, then click "UP" or "Down" button to select from 00-99-FL, which means 0%-99%-100% brightness, then click "Back" button to confirm.

**P-XXX** Means programs, total 1~31 programs.

**8-XX** Means RGB running effect's brightness, total 1~8 levels brightness

**SP-X** Means effect play speed. total 1~9 levels speed.

P-XX means RGB color changing modes, total 31 programs:

- 1- RGB off
- 2- Static red
- 3- Static green
- 4- Static blue
- 5- Static yellow (50% red + 50% green)
- 6- Static orange (75% red+25% green)
- 7- Static cyan (50% green+50% blue)
- 8- Static purple (50% blue+50% red)
- 9- Static white (100% red+100% green+100% blue)

09- Any two colors of RGB mix fade, changing diagram as follow:



10- RGB colors mix fade, changing diagram as follow:

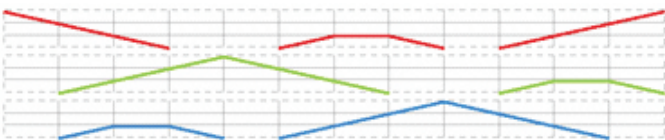

11- RGB FADE OUT & FADE IN, changing diagram as follow:



12- RGB jump changing, changing diagram as follow:

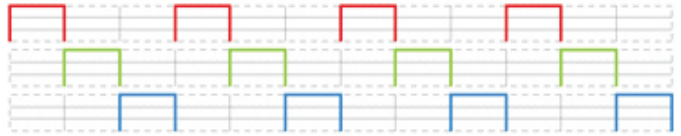

13- RGB FADE IN, changing diagram as follow:



14- RGB FADE OUT, changing diagram as follow:

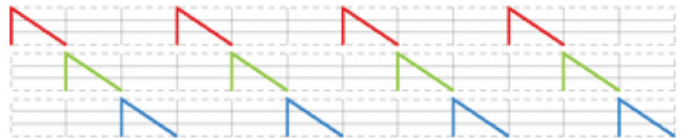

- 15- RGB 3 colors strobe
- 16- White color strobe (100% red+100% green+100% blue)
- 17- 7 colors FADE OUT & FADE IN (red, orange, yellow, green, cyan, blue, purple FADE OUT & FADE IN)
- 18- 7 colors jump changing (red, orange, yellow, green, cyan, blue, purple jump changing)
- 19- 7 colors strobe (red, orange, yellow, green, cyan, blue, purple strobe)
- 20- Red-white (100% red+100% green+100% blue) circle gradual changing
- 21- Green-white (100% red+100% green+100% blue) circle gradual changing
- 22- Blue-white (100% red+100% green+100% blue) circle gradual changing
- 23- Red-orange circle gradual changing
- 24- Red-purple circle gradual changing
- 25- Green-yellow circle gradual changing
- 26- Green-cyan circle gradual changing
- 27- Blue-purple circle gradual changing
- 28- Blue-cyan circle gradual changing
- 29- Red-yellow-green circle gradual changing
- 30- Red-purple-blue circle gradual changing
- 31- Green-cyan-blue circle gradual changing

## II. For run1 DMX decoder mod

After power on the decoder, if keep on clicking Up button, you will find below menu on display:

DMX signal indicator ●: When DMX signal input is detected, the indicator on the display following after 8 turns on red 8. XXX

- 8.XXX Means DMX address. factory defaults setting is 001.
- 88XX Means DMX channels quantity. factory defaults setting is Ch05
- 88XX Means Bit (8bit or 16bit). factory defaults setting is 16bit
- 88XX Means output PWM frequency. factory defaults setting is 1K HZ
- 88XX Means output dimming curve gamma value, factory defaults setting is ga 1.5
- 88XX Means Decoding mode, factory defaults setting is dp1.1

By holding button Back + Enter together at the same time over 5 seconds until the display go off, it will restore default settings.

### Wiring diagram

1. Work as Master mode

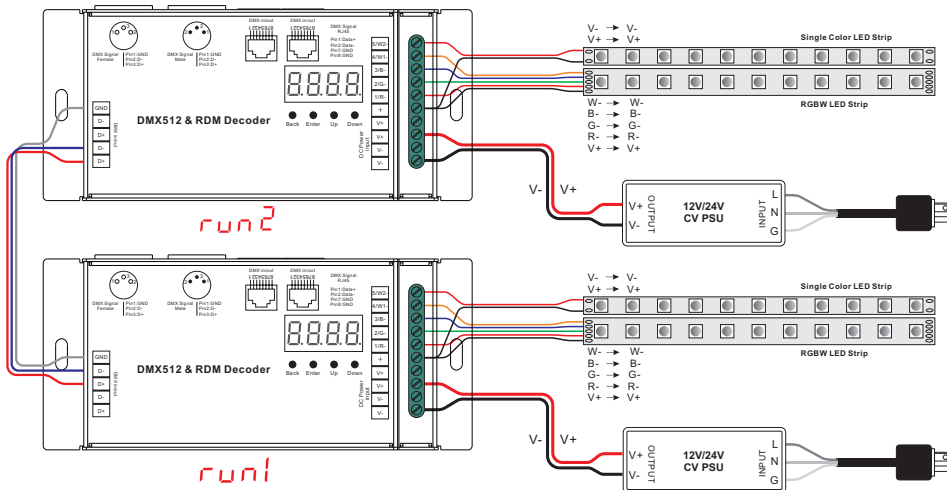

2. Work as Decoder mode

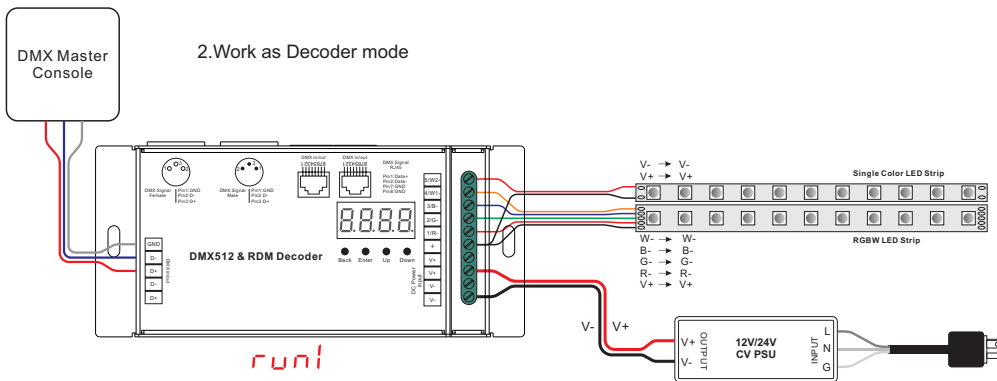

### 1. DMX address setting:

select menu XXX, click button "Enter", display flashes, then click or hold button "Up" / "Down" to set DMX address (click is slow, hold is fast.), then click button "Back" to confirm.

### 2. DMX channel quantity setting:

Select menu 88XX, click button "Enter", display flashes, then click button "Up" / "Down"

to set DMX channel quantity, then click button "Back" to confirm.

For example the DMX address is already set 001.

CH01=1 DMX address for all the output channels, which are all address 001.

CH02=2 DMX addresses, output 1&3 is address 001, output 2,4&5 is address 002

CH03=3 DMX addresses, output 1, 2 is address 001,002, output 3,4&5 is address 003

CH04=4 DMX addresses, output 1,2,3 is address 001,002,003, output 4&5 is address 004

CH05=5 DMX addresses, output 1,2,3,4,5 is address 001,002,003,004,005.

### 3. PWM output resolution Bit setting:

select menu 88XX, click button "Enter", display flashes, then click button "Up" / "Down"

to choose 08 or 16 bit, then click button "Back" to confirm.

### 4. output PWM frequency setting:

select menu 88XX, click button "Enter", display flashes, then click button "Up" / "Down" to

Choose 00~30 then click button "Back" to confirm. 00=500HZ, 01=1kHz, 02=2kHz.....30=30kHz.

### 5. output dimming curve gamma value setting:

select menu 88XX, click button "Enter", display flashes, then click or hold button "up"/"Down" to choose 0.1~9.9, then click button "Back" to confirm.

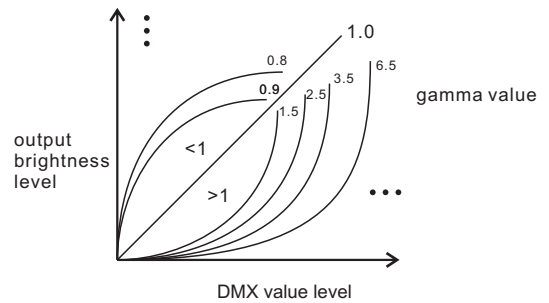

### 6. DMX decoding mode setting:

Select menu 88XX, click button "Enter", display flashes, then click or hold button "Up" / "Down" to choose the decoding mode, then click button "Back" to confirm.

"dPxx" means the DMX address quantity used for control of corresponding PWM output channel quantity. 1st "x" is DMX address quantity, 2nd "x" is PWM channel quantity.

Micro Dimming: the micro dimming effect can only be visible when the dimming curve gamma value is set lower than 1.4, and the lower the value is, the more visible the micro dimming effect will be.

**DMX address is 001, CH01**

DMX Console Slider number	dp1.1	dp2.1
DMX channel		
1	for all output dimming	for all output dimming
2	No use	for all output micro dimming

**DMX address is 001, CH04**

DMX Console Slider number	dp1.1	dp2.1	dp5.4	dp6.4
DMX channel				
1	for output 1 dimming	for output 1 dimming	for output 1 dimming	for output 1 dimming
2	for output 2 dimming	for output 1 micro dimming	for output 2 dimming	for output 2 dimming
3	for output 3 dimming	for output 2 dimming	for output 3 dimming	for output 3 dimming
4	for output 4&5 dimming	for output 2 micro dimming	for output 4&5 dimming	for output 4&5 dimming
5		for output 3 dimming	for all output master dimming	for all output master dimming
6		for output 3 micro dimming		strobe effects
7		for output 4 &5 dimming		
8		for output 4&5 micro dimming		

**DMX address is 001, CH02**

DMX Console Slider number	dp1.1	dp2.1	dp3.2
DMX channel			
1	for output 1&3 dimming	for output 1&3 dimming	for output 1&3 dimming
2	for output 2,4 &5 dimming	for output 1&3 micro dimming	for output 2,4 &5 dimming
3		for output 2,4 &5 dimming	for all output dimming
4		for output 2,4&5 micro dimming	

**DMX address is 001, CH05**

DMX Console Slider number	dp1.1	dp2.1	dp6.5	dp7.5
DMX channel				
1	for output 1 dimming	for output 1 dimming	for output 1 dimming	for output 1 dimming
2	for output 2 dimming	for output 1 micro dimming	for output 2 dimming	for output 2 dimming
3	for output 3 dimming	for output 2 dimming	for output 3 dimming	for output 3 dimming
4	for output 4 dimming	for output 2 micro dimming	for output 4 dimming	for output 4 dimming
5	for output 5 dimming	for output 3 dimming	for output 5 dimming	for output 5 dimming
6		for output 3 micro dimming	for all output master dimming	for all output master dimming
7		for output 4 dimming		strobe effects
8		for output 4 micro dimming		
9		for output 5 dimming		
10		for output 5 micro dimming		

**DMX address is 001, CH03**

DMX Console Slider number	dp1.1	dp2.1	dp4.3	dp5.3
DMX channel				
1	for output 1 dimming	for output 1 dimming	for output 1 dimming	for output 1 dimming
2	for output 2 dimming	for output 1 micro dimming	for output 2 dimming	for output 2 dimming
3	for output 3,4 &5 dimming	for output 2 dimming	for output 3,4&5 dimming	for output 3,4&5 dimming
4		for output 2 micro dimming	for all output master dimming	for all output master dimming
5		for output 3,4 &5 dimming		strobe effects
6		for output 3,4&5 micro dimming		

**The data definitions for strobe channel are as follows:**

{0, 7},//undefined  
 {8, 65},//slow strobe-->fast strobe  
 {66, 71},//undefined  
 {72, 127},//slow push fast close  
 {128, 133},//undefined  
 {134, 189},//slow close fast push  
 {190, 195},//undefined  
 {196, 250},//random strobe  
 {251, 255},//undefined

**The supported RDM PIDs are as follows:**

DISC\_UNIQUE\_BRANCH  
 DISC\_MUTE  
 DISC\_UN\_MUTE  
 DEVICE\_INFO  
 DMX\_START\_ADDRESS  
 IDENTIFY\_DEVICE  
 SOFTWARE\_VERSION\_LABEL  
 DMX\_PERSONALITY  
 DMX\_PERSONALITY\_DESCRIPTION  
 SLOT\_INFO  
 SLOT\_DESCRIPTION  
 MANUFACTURER\_LABEL  
 SUPPORTED\_PARAMETERS

**Restore to Factory Default Setting**

Press and hold down both "Back" and "Enter" keys until the digital display turns off, then release the keys, system will reset and the digital display will turn on again, all settings will be restored to factory default.

Default settings are as follows:

DMX Address Code: a001  
 DMX Address Quantity: SW1=0: ch05, SW1=1: ch04  
 PWM Resolution Mode: bt16  
 PWM Frequency: pf01  
 Gamma: ga1.5  
 Decoding Mode: dp1.1

