

# Instruction Manual

impression<sup>®</sup>  
X4BAR



from software version: v0.38



— since 1994 —

support@glp.de  
www.glp.de

## Contents

1	Description of Device .....	3
2	Safety Instructions .....	4
3	Mounting .....	6
3.1.1	Operating on the Floor (Upright).....	7
3.1.2	Mounting in hanging or sideways position .....	7
3.2	Securing the Fixture .....	7
3.3	Alignment of the Fixtures.....	8
3.4	Connections .....	8
3.4.1	Power Supply .....	8
3.4.2	DMX.....	9
4	The Menu Field .....	10
5	DMX Chanel Selection (DMX Protocol) .....	11
5.1	Normal Mode (norm) 34 DMX channels: .....	11
5.2	Compressed Mode (comp) 20 DMX Channels: .....	13
5.3	Dual Pixel Mode (dpix) 48 DMX Channels:.....	15
5.4	Single Pixel Mode (spix) 88 DMX Channels: .....	17
6	Accessories.....	21
6.1	Optional diffuser filter: .....	21
6.2	End Omega Bracket: .....	22
7	Maintaining and Cleaning .....	23
7.1	Safety regulations .....	23
7.2	Maintenance and Interval (rule-of-thumb).....	23
8	Technical Specifications: .....	24
9	Dimensions .....	25

# 1 Description of Device

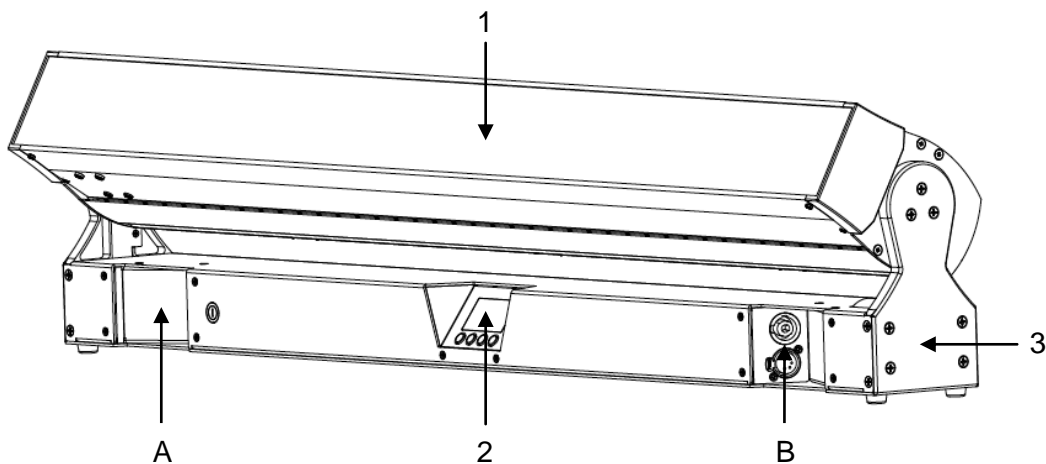

- 1. Moving Bar (actively and passively cooled)
- 2. LCD-Display / Menu (data entry)
- 3. Base with rubber feet and Camlock mounting system

## A) Base side left

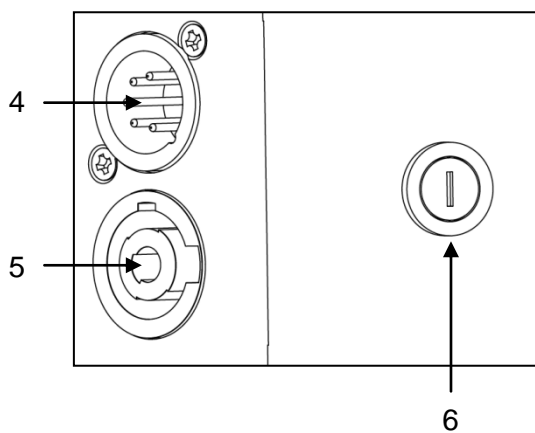

- 4. DMX Input (5 pin)
- 5. Mains Input (blue powerCON)
- 6. Micro-fuse 5x20mm, T5A

## B) Base side right

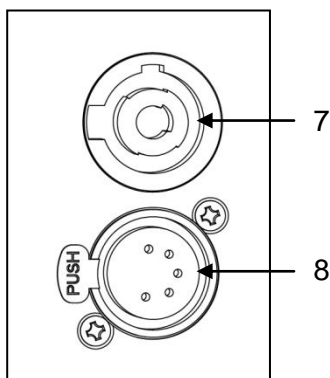

- 7. Mains Output (white powerCON)
- 8. DMX Output (5 pin)

## 2 Safety Instructions



The **IMPRESSION X4 Bar 20** is a High-Tech Product. To guarantee a smooth operation, it is necessary to respect the following rules. The manufacturer of this device will not take responsibility for damages through any disregard of the information provided in this manual. Warranty claims also will be voided in the case that the fixture housing is opened.



**Never look directly into the beam of light or into one of the LEDs.** **Attention:** LED Class 2M can cause injuries of your eyes even without optical instruments in front of them or within a distance of less than 0.5m and short exposure time.  
Hence: Avoid direct radiation into your eyes!



**WARNING:**

**Never let optical parts come in contact with alcohol, solvents or similar cleaners.**

1. Before powering on the fixture, make sure that the fixtures fans and air inlets are clean and not blocked.
2. Ensure that the fixture head can rotate unhindered throughout its complete range of pan and tilt movement. A safety distance of at least 0.5 m must be maintained between the fixture and any easily inflammable material (e.g. decoration material).
3. **Attention!** Don't touch the fixture during the operation. This can cause injuries and/or damages.
4. **The fixture doesn't contain any user serviceable parts. Opening the fixture will void all warranties.**
5. It is necessary to wait at least 15 minutes after disconnecting the mains power before handling the fixture. Pay attention to possible hot parts of the fixture.
6. To ensure safe operation, follow also the Installation guide described in the chapter below. Operating the **IMPRESSION X4 Bar 20** without suitable safety aids like Safety cables or clamps/hooks can increase the risk of an accident and must be avoided.
7. Repair, maintenance, and installation work shall be done by qualified or GLP certified staff only. You need to pay attention to the common rules of technology that are not explicitly mentioned in this manual.
8. Use only original GLP spare parts. Any structural modification of the system will terminate all warranty claims.
9. Please keep this instruction manual for future reference.



## Important Safety Information

The **IMPRESSION X4 Bar 20** fixture from GLP is fitted with a number of plano-convex lenses in a highly efficient collimator cluster. This type of lens can act as a strong magnifying glass.

If the rays from a strong light source (such as the sun or another lighting fixture) are directed towards the front of any of these fixtures, then internal damage may occur. In a worst case scenario with a high power light source this can happen very quickly, damaging the fixture internally, potentially melting components or causing an internal fire within seconds.

In order to avoid these possible problems please adhere to the following requirements:

- Do not expose the front of a fixture to direct sunlight or any other strong light sources.
- For outdoor applications during daylight make sure that the front face of any fixture is either shielded or points away from the sun, even when fixtures are not in use.
- Do not modify the front glass or lenses of any fixture.

These requirements have to be followed regardless of whether a fixture is powered on or off as the magnifying effect is an optical effect and therefore independent from the (electrical) state of the fixture.

Especially when working with high powered **beam-lights**; extreme caution and observance of these safety instructions is mandatory.

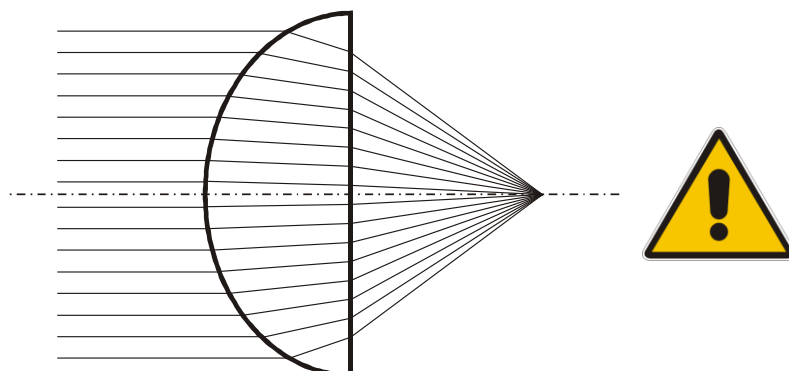

Should you have any questions about the operation of your fixture then please contact your local GLP office, or their authorized distributor, a list of which can be found at [www.glp.de](http://www.glp.de).

### 3 Mounting

The **IMPRESSION X4 Bar 20** is fully operational whether it hangs or is mounted to the wall. It can also be operated while standing on the floor. Keep a safety distance of min. 0.5 m towards any easily inflammable materials (decoration etc.).

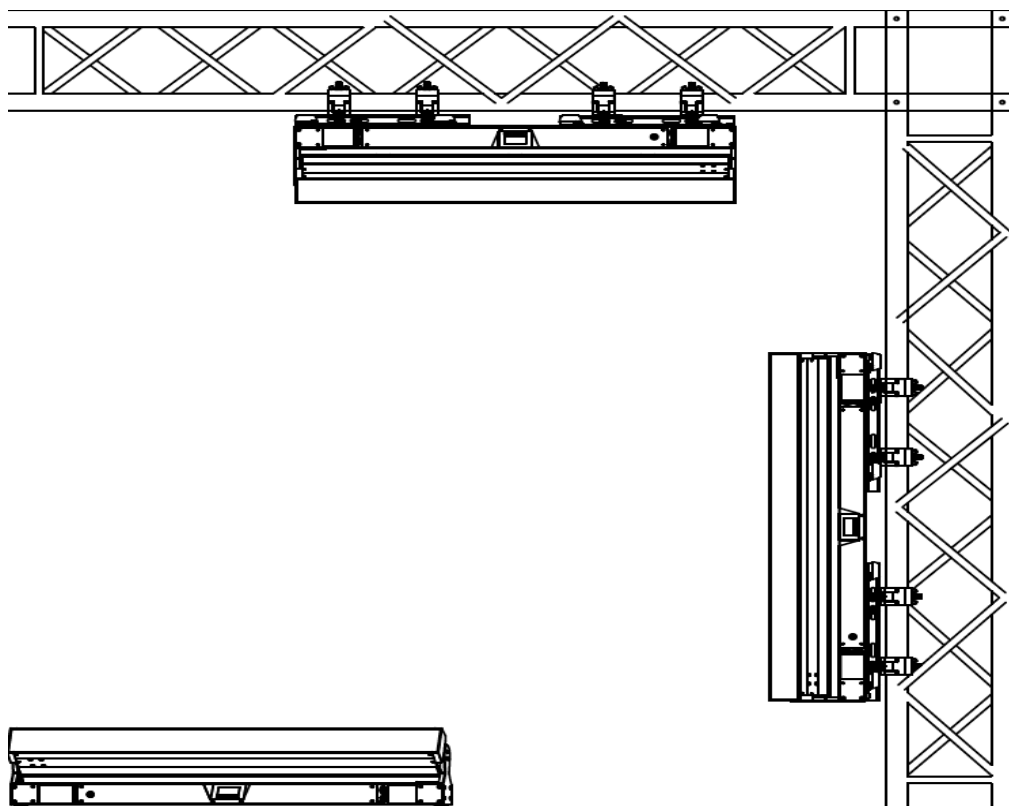

**Pay attention to the regulations of: BGV C1 (former VBG 70) and DIN VDE 0711-217.**

**The installation shall be done by qualified staff only.**

For the various mounting positions of the **IMPRESSION X4 Bar 20** (standing on the floor, sideways or hanging) different accessories kits are available. Through this a safe and firm installation is assured. You'll find dedicated connectors on the bottom side of the fixture which should be used.

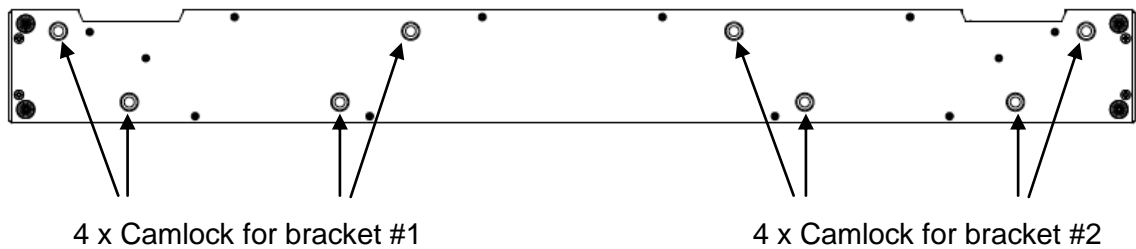

### 3.1.1 Operating on the Floor (Upright)

The **IMPRESSION X4 Bar 20** is fitted with 4x solid rubber feet which allows a stable standing of the fixture. An additional securing is usually not required. Please pay attention to an even and gripping surface.

### 3.1.2 Mounting in hanging or sideways position

To operate the **IMPRESSION X4 Bar 20** in a hanging position please use the two (2) dedicated brackets supplied with your fixture. They are fixed to the base of the fixture with fasteners called Camlock quick-release connectors. Insert the four fasteners of each and turn each 90° to lock them. Do the opposite to release them again.

## 3.2 Securing the Fixture

Regardless of the mounting method of the **IMPRESSION X4 Bar 20** you'll have to use a stipulated safety wire.

Attach the safety wire through the two attachment points shown below and connect it to the primary support structure.

The safety attachment points can be deployed by simply swinging them out from the base.

Pay attention to a safe and proper fastening. The safety cable must comply with BGI 810-3 (EN 60598-2-17 Section 17.6.6) and be capable of bearing a static suspended load that is ten times the weight of the fixture and all installed accessories.

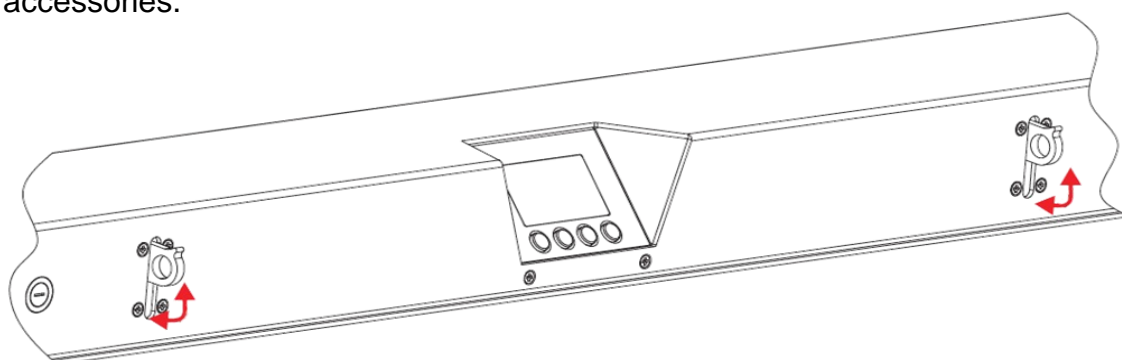

### 3.3 Alignment of the Fixtures

For precise and easy alignment of multiple fixtures the **IMPRESSION X4 Bar 20** is equipped with alignment pins on the side.

To deploy them, simply slide them to the side and insert the pins in the related holes of the next fixture.

Push the knob down to slide the pins in again after every usage to avoid any damage or injuries that could be caused by them.

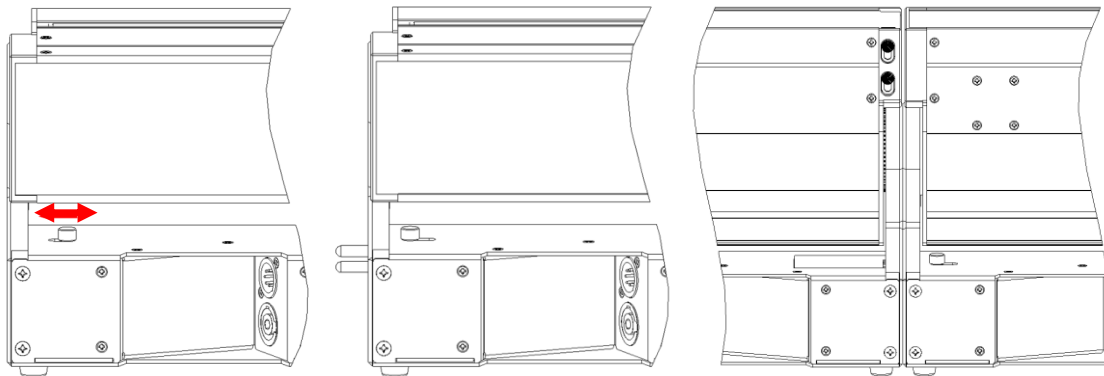

### 3.4 Connections

#### 3.4.1 Power Supply

~100-240 Volt AC, 50-60 Hz, powerCON AC connector

Connected load 450 VA (W) <=> T5A (micro-fuse 5x20mm)

Please see printing on the case for the right electronic supply!

**Disconnect from the mains supply for changing the fuse and use only the above described micro-fuse type.**

NEUTRIK® powerCON

The **IMPRESSION X4 Bar 20** is fitted with NEUTRIK® powerCON locking 3 conductor AC connectors.

The grey connector must be used to draw AC mains power from the fixtures` throughput sockets and the blue connectors must be used to supply power at the fixtures` power input socket.



The total number of fixtures in one interconnected chain depends on your local AC mains voltage but you must never connect more than a total load of 20A to stay within the limits of the connector. The total load includes all connected fixtures including the first one in the chain.

**Note: The maximum allowed total - load is 20A including the first fixture in one interconnected daisy chain.**

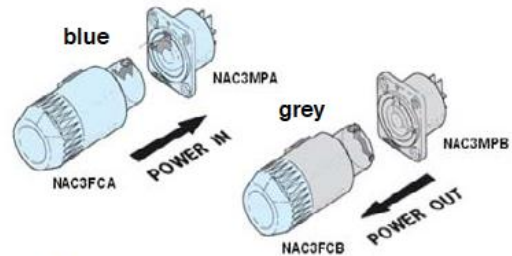

Picture: Courtesy of NEUTRIK® AG

### 3.4.2 DMX

USITT DMX-512 Standard input/output in 5-pin connectors.

Pin 1 = [Ground] / Pin 2 = [-] / Pin 3 = [+] / Pin 4&5 N.C.

The DMX- Addressing starts at the DMX- Address [001].

## 4 The Menu Field

You'll find the control board on the side part of the arm. It allows you to make all necessary adjustments of the **IMPRESSION X4 Bar**. With the Mode-key you get into the main menu. Afterwards you can Navigate through the menu with the Up/Down-keys. Push the Enter-key to get in the next menu level or to confirm your settings. Make them and set functions ON/OFF with the Up/Down-keys. Confirm and save it with the Enter-key (the display shows OK). Push the Mode-key to cancel the entry and go back to the main menu.

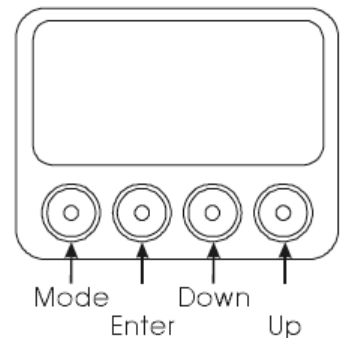

To lock or unlock the keys of the menu field press **Mode + Enter + Up** simultaneously.

### ← MODE - ENTER →

	Level 1	Level 2	Level 3	Level 4	Remark
	DMX Start Address 001				Set the DMX start address
	Special				Advanced settings
	Set DMX Mode				Select the desired DMX Mode
← DOWN - UP →		Compressed Mode			Fixture works in "Compressed" mode → see also section 4 below
		Normal Mode			Fixture works in "Normal" mode → see also section 4 below
		Single Pixel Mode			Fixture works in "Single Pixel" mode → see also section 4 below
	Position feedback				Switch automatic position feedback ON/OFF
	Reverse Tilt				Invert Tilt movements: ON/OFF
	Reset				RESET and new calibration for all functions

## 5 DMX Chanel Selection (DMX Protocol)

### 5.1 Normal Mode (norm) 34 DMX channels:

Channel	Function	Time and Value	DMX
<b>1 Tilt - High</b>	Tilt coarse	0° - 210°	0..255
<b>2 Tilt - Low</b>	Tilt fine		0..255
<b>3 Zoom</b>	Wide (flood) - narrow (spot)	50° - 7°	0..255
<b>4 CTO</b>	No CTO		0..7
	Continuous color temperature correction	Applicable for ALL colors	8..255
<b>5 Set 1 Color (fixed)</b>	Colors adjustable via RGB		0..7
	Color 01 - Red <sup>1)</sup>		8..15
	Color 02 - Amber <sup>1)</sup>		16..23
	Color 03 - Warm Yellow <sup>1)</sup>		24..31
	Color 04 - Yellow <sup>1)</sup>		32..39
	Color 05 - Green <sup>1)</sup>		40..47
	Color 06 - Turquoise <sup>1)</sup>		48..55
	Color 07 - Cyan <sup>1)</sup>		56..63
	Color 08 - Blue <sup>1)</sup>		64..71
	Color 09 - Lavender <sup>1)</sup>		72..79
	Color 10 - Malve <sup>1)</sup>		80..87
	Color 11 - Magenta <sup>1)</sup>		88..95
	Color 12 - Pink <sup>1)</sup>		96..103
	White - CTO	3200K	104..111
	White	5600K	112..119
White - CTB	7200K	120..127	
Rainbow Effect Stop <sup>2)</sup>		128	
Rainbow Effect <sup>3)</sup>	slow - fast	129..223	
Random colors	slow - fast	224..255	
<b>6 Set 1 Red</b>	Color mixing system - Red	0 - 100%	0..255
<b>7 Set 1 Green</b>	Color mixing system - Green	0 - 100%	0..255
<b>8 Set 1 Blue</b>	Color mixing system - Blue	0 - 100%	0..255
<b>9 Set 1 White</b>	Color mixing system - White	0 - 100%	0..255
<b>10 Set 1 Intensity</b>	Intensity	0 - 100%	0..255
<b>11 Shutter</b>	Shutter closed		0..15
	Shutter pulse random	slow – fast	16..47
	Fade on, snap off (random patterns)	slow – fast	48..79
	Snap on, fade off (random patterns)	slow – fast	80..111
	Fade on, fade off (random patterns)	slow – fast	112..143

	Strobe random	5s - 0.1s	144..199
	Strobe effect slow - fast	1 Hz - 10 Hz	200..239
	Shutter open		240..255
<b>12 Intensity</b>	Intensity	0 - 100%	0..255
<b>13 Special</b>	RESET	> 1 sec	250..255
<b>14 Set 2 Color</b> <sup>4)</sup>	Values see Channel 5	-	-
<b>15 Set 2 Red</b> <sup>4)</sup>	Color mixing system - Red	0 - 100%	0..255
<b>16 Set 2 Green</b> <sup>4)</sup>	Color mixing system - Green	0 - 100%	0..255
<b>17 Set 2 Blue</b> <sup>4)</sup>	Color mixing system - Blue	0 - 100%	0..255
<b>18 Set 2 White</b> <sup>4)</sup>	Color mixing system - White	0 - 100%	0..255
<b>19 Set 2 Intensity</b> <sup>4)</sup>	Intensity	0 - 100%	0..255
<b>20 Set 3 Color</b> <sup>4)</sup>	Values see Channel 5	-	-
<b>21 Set 3 Red</b> <sup>4)</sup>	Color mixing system - Red	0 - 100%	0..255
<b>22 Set 3 Green</b> <sup>4)</sup>	Color mixing system - Green	0 - 100%	0..255
<b>23 Set 3 Blue</b> <sup>4)</sup>	Color mixing system - Blue	0 - 100%	0..255
<b>24 Set 3 White</b> <sup>4)</sup>	Color mixing system - White	0 - 100%	0..255
<b>25 Set 3 Intensity</b> <sup>4)</sup>	Intensity	0 - 100%	0..255
<b>26 Crossfade</b>	0..2 seconds transistion time		0..255
<b>27 Star Effect</b>			0..255
<b>28 Set 1 Pattern Select</b>			0..255
<b>29 Set 1 Pattern Movement</b>			0..255
<b>30 Set 2 Pattern Select</b>			0..255
<b>31 Set 2 Pattern Movement</b>			0..255
<b>32 Pixel Select 1 - 8</b>			0..255
<b>33 Pixel Select 9 - 16</b>			0..255
<b>34 Pixel Select 17 - 20</b>			0..255

## 5.2 Compressed Mode (comp) 20 DMX Channels:

Channel	Function	Time and Value	DMX
<b>1 None</b>	reserved		-
<b>2 None</b>	reserved		-
<b>3 Tilt - High</b>	Tilt coarse	0° - 210°	0..255
<b>4 Tilt - Low</b>	Tilt fine		0..255
<b>5 Set 1 Color (fixed)</b>	Colors adjustable via RGB		0..7
	Color 01 - Red <sup>1)</sup>		8..15
	Color 02 - Amber <sup>1)</sup>		16..23
	Color 03 - Warm Yellow <sup>1)</sup>		24..31
	Color 04 - Yellow <sup>1)</sup>		32..39
	Color 05 - Green <sup>1)</sup>		40..47
	Color 06 - Turquoise <sup>1)</sup>		48..55
	Color 07 - Cyan <sup>1)</sup>		56..63
	Color 08 - Blue <sup>1)</sup>		64..71
	Color 09 - Lavender <sup>1)</sup>		72..79
	Color 10 - Malve <sup>1)</sup>		80..87
	Color 11 - Magenta <sup>1)</sup>		88..95
	Color 12 - Pink <sup>1)</sup>		96..103
	White - CTO	3200K	104..111
	White	5600K	112..119
	White - CTB	7200K	120..127
	Rainbow Effect Stop <sup>2)</sup>		128
	Rainbow Effect <sup>3)</sup>	slow - fast	129..223
	Random colors	slow - fast	224..255
<b>6 Set 1 Red</b>	Color mixing system - Red	0 - 100%	0..255
<b>7 Set 1 Green</b>	Color mixing system - Green	0 - 100%	0..255
<b>8 Set 1 Blue</b>	Color mixing system - Blue	0 - 100%	0..255
<b>9 Set 1 White</b>	Color mixing system - White	0 - 100%	0..255
<b>10 Shutter</b>	Shutter closed		0..15
	Shutter pulse random	slow – fast	16..47
	Fade on, snap off (random patterns)	slow – fast	48..79
	Snap on, fade off (random patterns)	slow – fast	80..111
	Fade on, fade off (random patterns)	slow – fast	112..143
	Strobe random	5s - 0.1s	144..199
	Strobe effect slow - fast	1 Hz - 10 Hz	200..239
	Shutter open		240..255
<b>11 Intensity</b>	Intensity	0 - 100%	0..255

<b>12 CTO</b>	No CTO Continuous color temperature correction	Applicable for ALL colors	0..7 8..255
<b>13 Special</b>	RESET	> 1 sec	250..255
<b>14 Crossfade</b>	0..2 seconds transistion time		0..255
<b>15 Set 1 Pattern Movement</b>			0..255
<b>16 Zoom</b>	Wide (flood) - narrow (spot)	50° - 7°	0..255
<b>17 Set 1 Pattern Select</b>			0..255
<b>18 Pixel Select 1 - 8</b>			0..255
<b>19 Pixel Select 9 - 16</b>			0..255
<b>20 Pixel Select 17 - 20</b>			0..255

### 5.3 Dual Pixel Mode (dpix) 48 DMX Channels:

Channel	Function	Time and Value	DMX
1 Tilt - High	Tilt coarse	0° - 210°	0..255
2 Tilt - Low	Tilt fine		0..255
3 Shutter	Shutter closed		0..15
	Shutter pulse random	slow – fast	16..47
	Fade on, snap off (random patterns)	slow – fast	48..79
	Snap on, fade off (random patterns)	slow – fast	80..111
	Fade on, fade off (random patterns)	slow – fast	112..143
	Strobe random	5s - 0.1s	144..199
	Strobe effect slow - fast	1 Hz - 10 Hz	200..239
	Shutter open		240..255
4 Intensity	Intensity	0 - 100%	0..255
5 CTO	No CTO		0..7
	Continuous color temperature correction	Applicable for ALL colors	8..255
6 Special	RESET	> 1 sec	250..255
7 Crossfade	0..2 seconds transistion time		0..255
8 Zoom	Wide (flood) - narrow (spot)	50° - 7°	0..255
9 Set 1&2 Red	Color mixing system - Red	0 - 100%	0..255
10 Set 1&2 Green	Color mixing system - Green	0 - 100%	0..255
11 Set 1&2 Blue	Color mixing system - Blue	0 - 100%	0..255
12 Set 1&2 White	Color mixing system - White	0 - 100%	0..255
13 Set 3&4 Red	Color mixing system - Red	0 - 100%	0..255
14 Set 3&4 Green	Color mixing system - Green	0 - 100%	0..255
15 Set 3&4 Blue	Color mixing system - Blue	0 - 100%	0..255
16 Set 3&4 White	Color mixing system - White	0 - 100%	0..255
17 Set 5&6 Red	Color mixing system - Red	0 - 100%	0..255
18 Set 5&6 Green	Color mixing system - Green	0 - 100%	0..255
19 Set 5&6 Blue	Color mixing system - Blue	0 - 100%	0..255
20 Set 5&6 White	Color mixing system - White	0 - 100%	0..255
21 Set 7&8 Red	Color mixing system - Red	0 - 100%	0..255
22 Set 7&8 Green	Color mixing system - Green	0 - 100%	0..255
23 Set 7&8 Blue	Color mixing system - Blue	0 - 100%	0..255
24 Set 7&8 White	Color mixing system - White	0 - 100%	0..255
25 Set 9&10 Red	Color mixing system - Red	0 - 100%	0..255
26 Set 9&10 Green	Color mixing system - Green	0 - 100%	0..255
27 Set 9&10 Blue	Color mixing system - Blue	0 - 100%	0..255

<b>28 Set 9&amp;10 White</b>	Color mixing system - White	0 - 100%	0..255
<b>29 Set 11&amp;12 Red</b>	Color mixing system - Red	0 - 100%	0..255
<b>30 Set 11&amp;12 Green</b>	Color mixing system - Green	0 - 100%	0..255
<b>31 Set 11&amp;12 Blue</b>	Color mixing system - Blue	0 - 100%	0..255
<b>32 Set 11&amp;12 White</b>	Color mixing system - White	0 - 100%	0..255
<b>33 Set 13&amp;14 Red</b>	Color mixing system - Red	0 - 100%	0..255
<b>34 Set 13&amp;14 Green</b>	Color mixing system - Green	0 - 100%	0..255
<b>35 Set 13&amp;14 Blue</b>	Color mixing system - Blue	0 - 100%	0..255
<b>36 Set 13&amp;14 White</b>	Color mixing system - White	0 - 100%	0..255
<b>37 Set 15&amp;16 Red</b>	Color mixing system - Red	0 - 100%	0..255
<b>38 Set 15&amp;16 Green</b>	Color mixing system - Green	0 - 100%	0..255
<b>39 Set 15&amp;16 Blue</b>	Color mixing system - Blue	0 - 100%	0..255
<b>40 Set 15&amp;16 White</b>	Color mixing system - White	0 - 100%	0..255
<b>41 Set 17&amp;18 Red</b>	Color mixing system - Red	0 - 100%	0..255
<b>42 Set 17&amp;18 Green</b>	Color mixing system - Green	0 - 100%	0..255
<b>43 Set 17&amp;18 Blue</b>	Color mixing system - Blue	0 - 100%	0..255
<b>44 Set 17&amp;18 White</b>	Color mixing system - White	0 - 100%	0..255
<b>45 Set 19&amp;20 Red</b>	Color mixing system - Red	0 - 100%	0..255
<b>46 Set 19&amp;20 Green</b>	Color mixing system - Green	0 - 100%	0..255
<b>47 Set 19&amp;20 Blue</b>	Color mixing system - Blue	0 - 100%	0..255
<b>48 Set 19&amp;20 White</b>	Color mixing system - White	0 - 100%	0..255



#### 5.4 Single Pixel Mode (spix) 88 DMX Channels:

Channel	Function	Time and Value	DMX
1 Tilt - High	Tilt coarse	0° - 210°	0..255
2 Tilt - Low	Tilt fine		0..255
3 Shutter	Shutter closed		0..15
	Shutter pulse random	slow – fast	16..47
	Fade on, snap off (random patterns)	slow – fast	48..79
	Snap on, fade off (random patterns)	slow – fast	80..111
	Fade on, fade off (random patterns)	slow – fast	112..143
	Strobe random	5s - 0.1s	144..199
	Strobe effect slow - fast	1 Hz - 10 Hz	200..239
	Shutter open		240..255
4 Intensity	Intensity	0 - 100%	0..255
5 CTO	No CTO		0..7
	Continuous color temperature correction	Applicable for ALL colors	8..255
6 Special	RESET	> 1 sec	250..255
7 Crossfade	0..2 seconds transistion time		0..255
8 Zoom	Wide (flood) - narrow (spot)	50° - 7°	0..255
9 Set 1 Red	Color mixing system - Red	0 - 100%	0..255
10 Set 1 Green	Color mixing system - Green	0 - 100%	0..255
11 Set 1 Blue	Color mixing system - Blue	0 - 100%	0..255
12 Set 1 White	Color mixing system - White	0 - 100%	0..255
13 Set 2 Red	Color mixing system - Red	0 - 100%	0..255
14 Set 2 Green	Color mixing system - Green	0 - 100%	0..255
15 Set 2 Blue	Color mixing system - Blue	0 - 100%	0..255
16 Set 2 White	Color mixing system - White	0 - 100%	0..255
17 Set 3 Red	Color mixing system - Red	0 - 100%	0..255
18 Set 3 Green	Color mixing system - Green	0 - 100%	0..255
19 Set 3 Blue	Color mixing system - Blue	0 - 100%	0..255
20 Set 3 White	Color mixing system - White	0 - 100%	0..255
21 Set 4 Red	Color mixing system - Red	0 - 100%	0..255
22 Set 4 Green	Color mixing system - Green	0 - 100%	0..255
23 Set 4 Blue	Color mixing system - Blue	0 - 100%	0..255
24 Set 4 White	Color mixing system - White	0 - 100%	0..255
25 Set 5 Red	Color mixing system - Red	0 - 100%	0..255
26 Set 5 Green	Color mixing system - Green	0 - 100%	0..255
27 Set 5 Blue	Color mixing system - Blue	0 - 100%	0..255

<b>28 Set 5 White</b>	Color mixing system - White	0 - 100%	0..255
<b>29 Set 6 Red</b>	Color mixing system - Red	0 - 100%	0..255
<b>30 Set 6 Green</b>	Color mixing system - Green	0 - 100%	0..255
<b>31 Set 6 Blue</b>	Color mixing system - Blue	0 - 100%	0..255
<b>32 Set 6 White</b>	Color mixing system - White	0 - 100%	0..255
<b>33 Set 7 Red</b>	Color mixing system - Red	0 - 100%	0..255
<b>34 Set 7 Green</b>	Color mixing system - Green	0 - 100%	0..255
<b>35 Set 7 Blue</b>	Color mixing system - Blue	0 - 100%	0..255
<b>36 Set 7 White</b>	Color mixing system - White	0 - 100%	0..255
<b>37 Set 8 Red</b>	Color mixing system - Red	0 - 100%	0..255
<b>38 Set 8 Green</b>	Color mixing system - Green	0 - 100%	0..255
<b>39 Set 8 Blue</b>	Color mixing system - Blue	0 - 100%	0..255
<b>40 Set 8 White</b>	Color mixing system - White	0 - 100%	0..255
<b>41 Set 9 Red</b>	Color mixing system - Red	0 - 100%	0..255
<b>42 Set 9 Green</b>	Color mixing system - Green	0 - 100%	0..255
<b>43 Set 9 Blue</b>	Color mixing system - Blue	0 - 100%	0..255
<b>44 Set 9 White</b>	Color mixing system - White	0 - 100%	0..255
<b>45 Set 10 Red</b>	Color mixing system - Red	0 - 100%	0..255
<b>46 Set 10 Green</b>	Color mixing system - Green	0 - 100%	0..255
<b>47 Set 10 Blue</b>	Color mixing system - Blue	0 - 100%	0..255
<b>48 Set 10 White</b>	Color mixing system - White	0 - 100%	0..255
<b>49 Set 11 Red</b>	Color mixing system - Red	0 - 100%	0..255
<b>50 Set 11 Green</b>	Color mixing system - Green	0 - 100%	0..255
<b>51 Set 11 Blue</b>	Color mixing system - Blue	0 - 100%	0..255
<b>52 Set 11 White</b>	Color mixing system - White	0 - 100%	0..255
<b>53 Set 12 Red</b>	Color mixing system - Red	0 - 100%	0..255
<b>54 Set 12 Green</b>	Color mixing system - Green	0 - 100%	0..255
<b>55 Set 12 Blue</b>	Color mixing system - Blue	0 - 100%	0..255
<b>56 Set 12 White</b>	Color mixing system - White	0 - 100%	0..255
<b>57 Set 13 Red</b>	Color mixing system - Red	0 - 100%	0..255
<b>58 Set 13 Green</b>	Color mixing system - Green	0 - 100%	0..255
<b>59 Set 13 Blue</b>	Color mixing system - Blue	0 - 100%	0..255
<b>60 Set 13 White</b>	Color mixing system - White	0 - 100%	0..255
<b>61 Set 14 Red</b>	Color mixing system - Red	0 - 100%	0..255
<b>62 Set 14 Green</b>	Color mixing system - Green	0 - 100%	0..255
<b>63 Set 14 Blue</b>	Color mixing system - Blue	0 - 100%	0..255
<b>64 Set 14 White</b>	Color mixing system - White	0 - 100%	0..255
<b>65 Set 15 Red</b>	Color mixing system - Red	0 - 100%	0..255

<b>66 Set 15 Green</b>	Color mixing system - Green	0 - 100%	0..255
<b>67 Set 15 Blue</b>	Color mixing system - Blue	0 - 100%	0..255
<b>68 Set 15 White</b>	Color mixing system - White	0 - 100%	0..255
<b>69 Set 16 Red</b>	Color mixing system - Red	0 - 100%	0..255
<b>70 Set 16 Green</b>	Color mixing system - Green	0 - 100%	0..255
<b>71 Set 16 Blue</b>	Color mixing system - Blue	0 - 100%	0..255
<b>72 Set 16 White</b>	Color mixing system - White	0 - 100%	0..255
<b>73 Set 17 Red</b>	Color mixing system - Red	0 - 100%	0..255
<b>74 Set 17 Green</b>	Color mixing system - Green	0 - 100%	0..255
<b>75 Set 17 Blue</b>	Color mixing system - Blue	0 - 100%	0..255
<b>76 Set 17 White</b>	Color mixing system - White	0 - 100%	0..255
<b>77 Set 18 Red</b>	Color mixing system - Red	0 - 100%	0..255
<b>78 Set 18 Green</b>	Color mixing system - Green	0 - 100%	0..255
<b>79 Set 18 Blue</b>	Color mixing system - Blue	0 - 100%	0..255
<b>80 Set 18 White</b>	Color mixing system - White	0 - 100%	0..255
<b>81 Set 19 Red</b>	Color mixing system - Red	0 - 100%	0..255
<b>82 Set 19 Green</b>	Color mixing system - Green	0 - 100%	0..255
<b>83 Set 19 Blue</b>	Color mixing system - Blue	0 - 100%	0..255
<b>84 Set 19 White</b>	Color mixing system - White	0 - 100%	0..255
<b>85 Set 20 Red</b>	Color mixing system - Red	0 - 100%	0..255
<b>86 Set 20 Green</b>	Color mixing system - Green	0 - 100%	0..255
<b>87 Set 20 Blue</b>	Color mixing system - Blue	0 - 100%	0..255
<b>88 Set 20 White</b>	Color mixing system - White	0 - 100%	0..255

The Pixel are numbered left to right 1 – 20 as shown below.

Tilt DMX Value = 0 / “Display” to the front / “Power & DMX In” to the left.

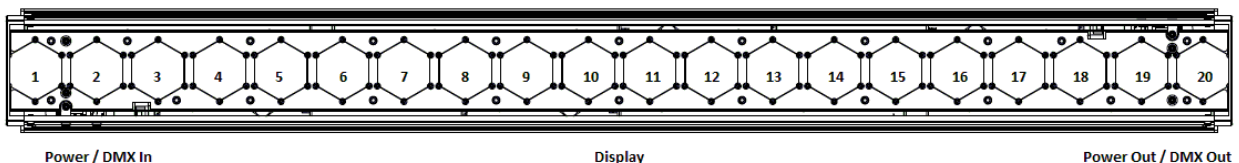

<sup>1)</sup> The predefined colors can be used as start-colors for the Rainbow effect. Please select first a desired start-color before you activate the rainbow effect. All **IMPRESSION X4 Bar 20** will then start from that color and will execute the rainbow effect synchronously. Different **IMPRESSION X4 Bar 20** can have different start-colors but will still execute the rainbow effect synchronously. If you choose a color different from the ones marked with <sup>1)</sup> in the tables above the rainbow start-color will be red.

<sup>2)</sup> Rainbow-effect Stop will pause this function. After resuming the rainbow-effect will be continued from the current color.

<sup>3)</sup> The Rainbow-effect will run synchronously only if started from one of the predefined colors (see also <sup>1)</sup> before).

## 6 Accessories

### 6.1 Optional diffuser filter:

The clear acrylic front cover is exchangeable with different diffusion or frost filters. A diffusion filter with 5° vertical & 30° horizontal spread is already included with your **impression X4 Bar 20**.

For other filter options please contact your local GLP dealer.

To remove the installed cover pull down the latch shown below and pull the filter out.

To insert the new filter pull the latch down again and slide in the new filter until fully inserted, then release the latch to secure the new filter.

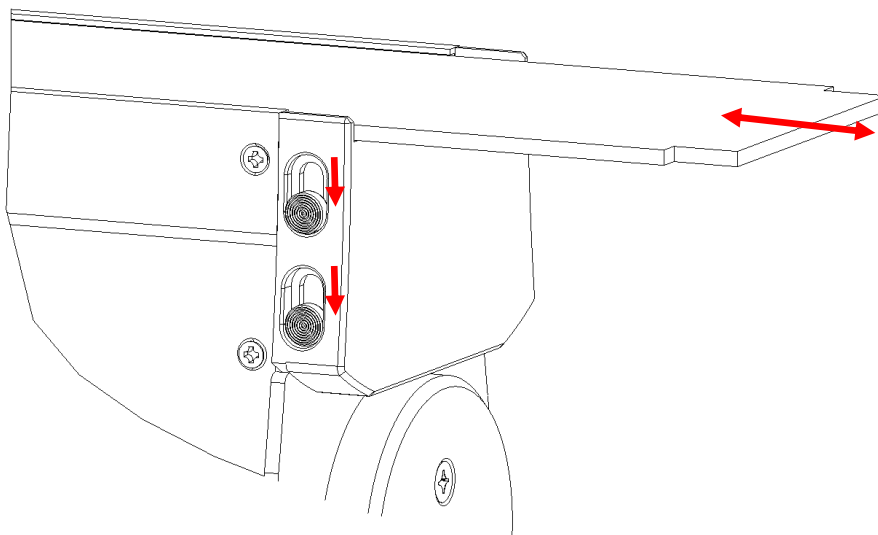

## 6.2 End Omega Bracket:

To hang the **impression X4 Bar 20** vertically from one end of the unit instead of the backside, there is an optional End-Omega Bracket available as Accessory.

Contact your local dealer or GLP Office for further details.

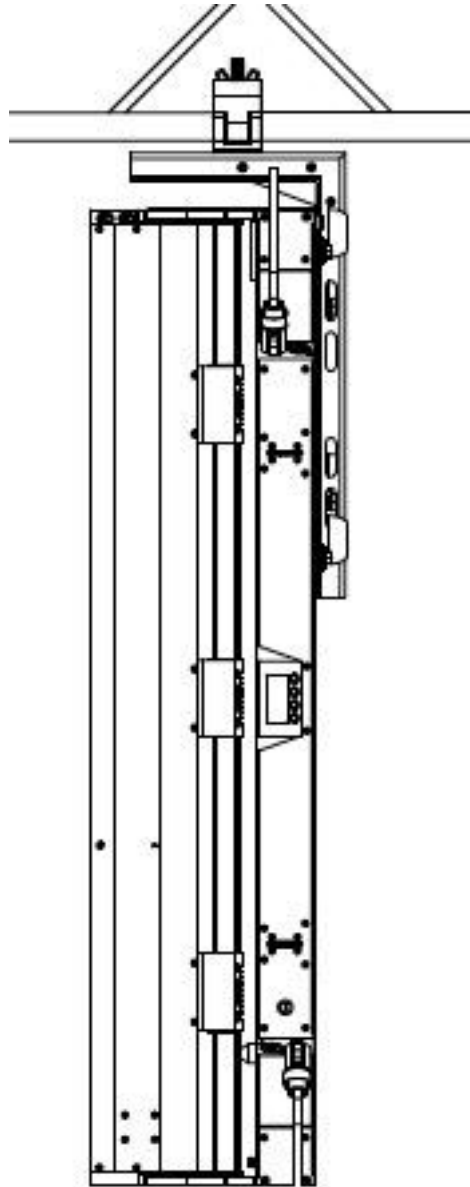

## 7 Maintaining and Cleaning

The **IMPRESSION X4 Bar 20** is a fixture of very low maintenance. It is only necessary to clean the air inlets and outlets as well as the optical LED lenses from time to time. For safe operation it is absolutely essential that the fixture is kept clean and that dust, dirt and smoke-fluid residues must not build up on, or within the fixture. Otherwise the fixture's light-output will be significantly reduced or damages can occur. Regular cleaning will not only ensure the maximum light-output, but will also allow the fixture to operate reliably throughout its life.

**A soft lint-free cloth moistened with any good glass cleaning fluid is recommended to clean the lenses.**



**Attention:**

**Under no circumstances should alcohol or solvents be used to clean the lenses!**

### 7.1 Safety regulations

- **Pull out the mains power plug!**
- Wait min. 15 minutes after disconnecting power to allow the fixture to cool down.

### 7.2 Maintenance and Interval (rule-of-thumb)

The contamination of the fixture depends on the environment details. Hence no general guidelines can be given. The intervals given below are only suggestions from our experience.

Position	Interval	In this way
LED reflector and optical system	weekly	soft brush /lint-free cloth
Fan and air channel	monthly	vacuum cleaner, airbrush, etc.

**Attention:**

- **Never let optical parts come into contact with oil, fat, alcohol or similar solvents.**
- **Before running the fixture wait until all parts are dry.**
- **Never touch lenses with bare fingers.**

## 8 Technical Specifications:

<b>Power supply</b>	
<b>Power consumption</b>	450 VA (Watt)
<b>Power Input</b>	Auto sensing 100-240 V AC, 50-60 Hz
<b>Fuse protection</b>	Micro-fuse 5x20 mm, T5A
<b>Operational Parameters</b>	
<b>Max. Ambient Temperature</b>	5° - 45°C (integrated overheating switch) 40°-113°F
<b>Mounting Position</b>	Any (see relevant chapter in the manual)
<b>Lighting System - Additive Color mixing</b>	
<b>LED Type</b>	20 x Osram Ostar RGBW multi-chip
<b>Lifetime</b>	50,000 h
Wavelength optimized for maximum presentable color space	
<b>Optical System</b>	
Full RGBW / High efficient Collimator cluster Exchangeable diffuser filters available (optional).	
<b>Shutter / Dimmer (8/16 Bit)</b>	
Strobe- Effect with variable speed between 1-10 flashes per second, Random- & Pulse-Effects Continuous Dimmer 0 - 100%	
<b>Zoom</b>	
7 to 50 degree continuous high speed zoom	
<b>Optical Patterns</b>	
Several pre-defined beam patterns with direct access and manipulation. Free control of every pixel, color and intensity	
<b>DMX Control</b>	
Standard USITT DMX-512, 5 pin XLR: [+]=Pin 3 / [-]=Pin 2 / [Ground]=Pin 1 / Pin 4&5 N.C. The DMX- Addressing starts at the DMX channel [001].	
<b>Tilt (8/16 Bit)</b>	
<b>Tilt- movement</b>	210° in min. 1.5 seconds (Position Feedback)
<b>Weights and Measures</b>	
<b>Length</b>	1000 mm / 39.4''
<b>Width</b>	100 mm / 3.9''
<b>Height</b>	240 mm / 9.4''
<b>Weight (net)</b>	14.5 kg / 32 lbs
<b>Weight with 2 brackets</b>	16 kg / 35 lbs



## 9 Dimensions

