





UNLESS OTHERWISE SPECIFIED	DRW:	PART NO.:		 GERMAN LIGHT PRODUCTS GMBH IM STOECKMAEDLE 13 76307 KARLSBAD - GERMANY PHONE: +49 (0)7248/92719-0 WWW.GLP.DE
	CHK:	DRAWING NO.:		
DIMENSIONAL TOLERANCES: <6 = ± 0.05 6-30 = ± 0.1 30-120 = ± 0.15 >120 = ± 0.2 ANGLES = ± 0.5 °	APR:	DATE: 19.10.10	REV.: 0	 PRODUCTS
	PROPRIETARY NOTICE:	DESCRIPTION:		
ALL INFORMATION HEREIN IS THE SOLE AND EXCLUSIVE PROPERTY OF GLP, AND MAY NOT BE USED, DISCLOSED OR REPRODUCED IN ANY MANNER WITHOUT THE ADVANCE WRITTEN CONSENT OF GLP.	SIZE A4		MATERIAL:	
	THIRD ANGLE PROJ. 		FINISH:	
	ALL DIMENSIONS ARE IN MILLIMETERS UNLESS NOTED OTHERWISE. REMOVE ALL BURRS AN SHARP EDGES.			FILENAME: MEISTERSTUECK
DO NOT SCALE		SCALE 1:10		SHEET 1 OF 2

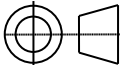
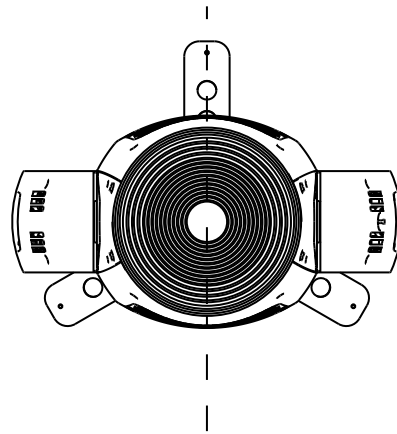
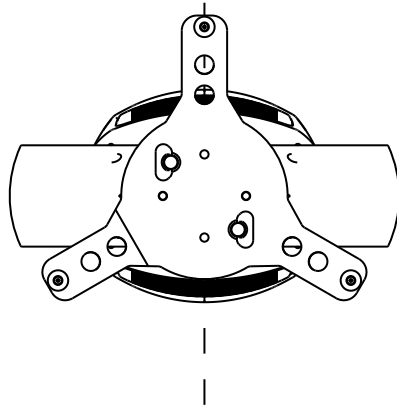

UNLESS OTHERWISE SPECIFIED DIMENSIONAL TOLERANCES: <6 =± 0.05 6-30 =± 0.1 30-120 =± 0.15 >120 =± 0.2 ANGLES =± 0.5 ° PROPRIETARY NOTICE: ALL INFORMATION HEREIN IS THE SOLE AND EXCLUSIVE PROPERTY OF GLP, AND MAY NOT BE USED, DISCLOSED OR REPRODUCED IN ANY MANNER WITHOUT THE ADVANCE WRITTEN CONSENT OF GLP.	DRW:	PART NO.:		 GERMAN LIGHT PRODUCTS GMBH IM STOECKMAEDLE 13 76307 KARLSBAD - GERMANY  PHONE: +49 (0)7248/92719-0 WWW.GLP.DE
	CHK:	DRAWING NO.:		
	APR:	DATE: 19.10.10	REV.: 0	
	SIZE A4 THIRD ANGLE PROJ.	DESCRIPTION:		
	MATERIAL: 0	FINISH:		
	ALL DIMENSIONS ARE IN MILLIMETERS UNLESS NOTED OTHERWISE. REMOVE ALL BURRS AN SHARP EDGES.		FILENAME: MEISTERSTUECK	
	DO NOT SCALE	SCALE 1:10	SHEET 2 OF 2	